



Dedicated to Our Customers' Success.



2500TM Short Mast



2500TM Long Mast (Oil Field)



2500CM Long Mast

2500 Series

Truck & Crawler Mounts

**Made in America
Best in the World**

2500 Technical Specifications

	MECHANICAL		HYDRAULIC	
Torque	90,000 lb-ft	122 kNm	90,000 lb-ft	122 kNm
Spinoff	147 RPM	147 RPM	70 RPM	70 RPM
Recommended Drill Diameter	36-76 in	914 -1930 mm	36-76 in	914 -1930 mm
Crowd Down • Pull up	24,000 • 18,000 lbs	107 • 80 kN	24,000 • 18,000 lbs	107 • 80 kN
Kelly Winch Line Pull	25,000 lbs	111 kN	25,000 lb	111 kN
Kelly Winch Line Speed • Cable Size	145 ft/min • 3/4" dia	44 m/min • 19 mm	145 ft/min • 3/4" dia	44 m/min • 19 mm
Service Winch Line Pull • Cable Size	12,000 lbs • 1/2" dia	53 kN • 13 mm	12,000 lbs • 1/2" dia	53 kN • 13 mm
Engine (John Deere)	4045 (Tier 3 or 4)		4045 (Tier 3 or 4)	
Power Unit	173 HP • 129kW		173 HP • 129kW	
Transmission Speeds	6 FWD/ 3 REV		variable	

2500 Standard Features

Rotary (Mechanical)	Single reduction with heavy duty spiral bevel ring gear and pinion. Roller type kelly drive.
Mast	Lattice type structure. Mast is elevated with two independently controlled hydraulic cylinders that allow positioning 10 degrees past vertical and 10 degrees each side.
Kelly	Telescoping multi-element. Square friction or round locking. Customized Kelly stub per customer specification.
Kelly Winch	"Controlled freefall" or straight power down when lowering and 2 speed 25,000 lb raise.
Service Winch	12,000 lb. power-up/power-down.
Rotating Frame	Rotation provided by dual swing rotation motors and planetary drives with integral braking system. Enables 360° swing on crawler rigs.
Slide Frame	88" slide on truck mount and 42" on crawler mount increases drill radius for maximum drill radius of 156"(13') and 144"(12') respectively.
Truck Mount (TM)	8x4 truck, typical gross vehicle weight (GVW) rating is 70,000 lb. Varies depending on configuration. Outriggers are out/down on cab end and stabilizers on drill end. Powered by upper unit and controlled at drill operator console.
Crawler Mount (CM)	24" wide triple grouser pads on 14 ft long expandable track frames on custom carbody. 10 ft width for transport to 12 ft for increased stability when drilling. Standard weight of 64,000 lbs applies 7.94 psi on track pads in standard configuration. Two speed travel of independently controlled tracks.

Note: Both the truck mount and crawler mount are offered with a mechanical or hydraulic driven rotary allowing a wider range of kelly options.

2500 Additional Options

- A-frame or expandable outriggers on drill end
- Solid 4.25" inner Kelly bar
- Deck extension
- Water tank
- Tool boxes
- Free fall service winch
- Working lights
- Kelly/mast configuration for alternate drill depths
- Umbrella installation
- Operator's cab with heater and air conditioning
- Cold weather heating package
- Reaction jack
- Work platforms

2500 Drill Depths

KELLY BAR					MAST HEIGHT			
					29.5 ft • 9 m	35 ft • 10.7 m	54 ft • 16.4 m	61 ft • 18.6 m
BAR TYPE		BARS	BAR DIMENSIONS		KELLY PENETRATION DEPTH			
MECH	Square	2	6/4.25 in	152/108 mm	21 ft 6.4 m	34 ft 10.3 m	56 ft 17.1 m	76 ft 23.2 m
	Square	3	8/6/4.25 in	203/152/108 mm	38 ft 11.5 m	54 ft 16.4 m	86 ft 26.2 m	116 ft 35.4 m
HYDRLC	Square	4	10/8/6/4.25 in	254/203/152/108 mm	54 ft 16.4 m	70 ft 21.3 m	116 ft 35.4 m	156 ft 47.5 m
	Round	2	10.75/8.62 in	273/219 mm	22 ft 6.7 m	33 ft 10 m	75 ft 22.9 m	76 ft 23.2 m
	Round	3	12.75/10.75/8.62 in	324/273/219 mm	37 ft 11.2 m	52 ft 15.8 m	86 ft 26.2 m	116 ft 35.4 m

Note: Kelly penetration depth does not include tool length.

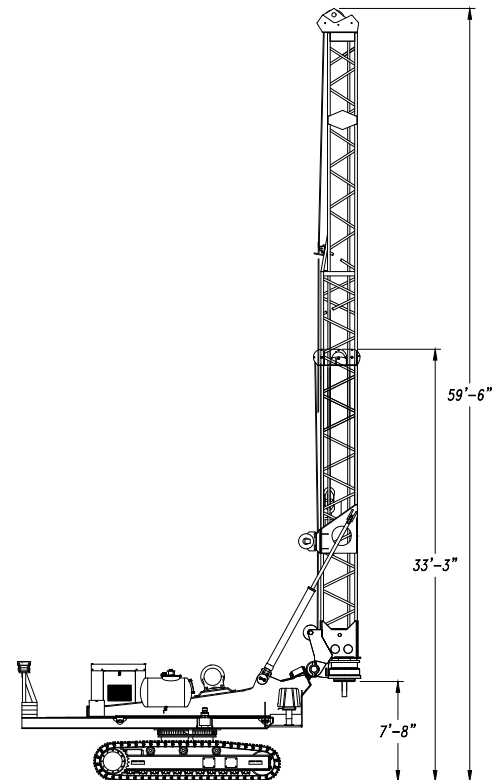
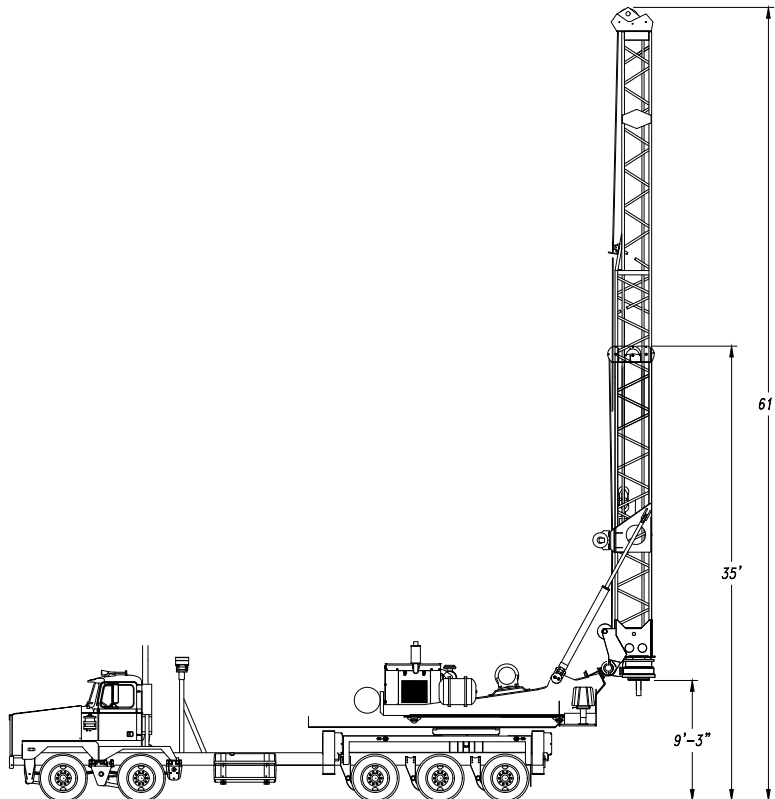
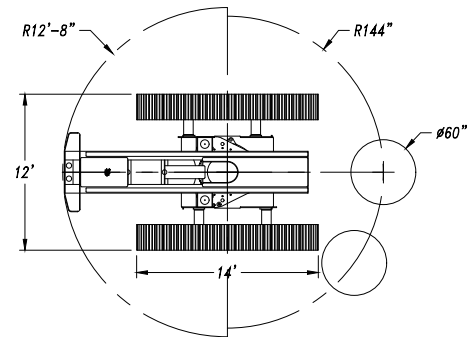
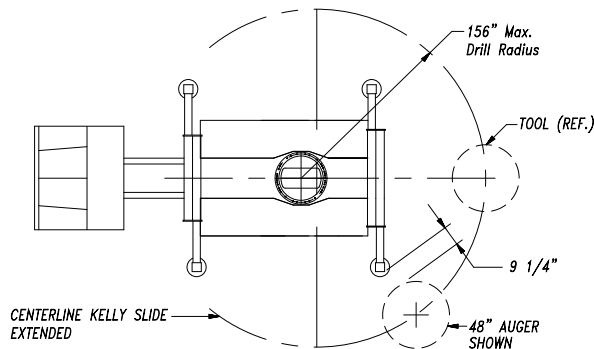

2500 Maximum Drill Radius

MOUNT	DRILL RADIUS (MAXIMUM)	ROTARY CLEARANCE	SLIDE	MAST TILT (L/R/OB)
Truck (TM)	156 in • 3,962 mm	110 in • 2,794 mm	88 in • 2,235 mm	10° / 10° / 10°
Crawler (CM)	144 in • 3,658 mm	92 in • 2,337 mm	42 in • 1,067 mm	10° / 10° / 10°

2500 Travel Configurations

MOUNT	MAST HEIGHT		WEIGHT		TRAVEL HEIGHT		TRAVEL LENGTH		TRAVEL WIDTH	
Truck (TM)	35 ft	10.7 m	68,000 lbs	30,844 kgs*	13 ft-6 in	4.1 m*	35 ft	10.7 m	8 ft-6 in	2.6 m
Truck (TM)	53 ft-5 in	16.3 m	70,000 lbs	31,751 kgs*	13 ft-6 in	4.1 m*	46 ft-6 in	14.1 m	8 ft-6 in	2.6 m
Truck (TM)	61 ft	18.6 m	82,000 lbs	37,194 kgs*	13 ft-6 in	4.1 m*	54 ft-6 in	16.6 m	8 ft-6 in	2.6 m
Crawler (CM)	33 ft-6 in	10.2 m	60,000 lbs	27,215 kgs	12 ft-3 in	3.7 m	26 ft-5 in	8 m	10 ft	3 m
Crawler (CM)	51ft-6 in	15.7 m	62,000 lbs	28,123 kgs	12 ft-3 in	3.7 m	45 ft	13.7 m	10 ft	3 m
Crawler (CM)	59 ft-6 in	18.1 m	64,000 lbs	29,029 kgs	12 ft-3 in	3.7 m	53 ft	16.1 m	10 ft	3 m

*Truck mount weights and travel heights are approximate.

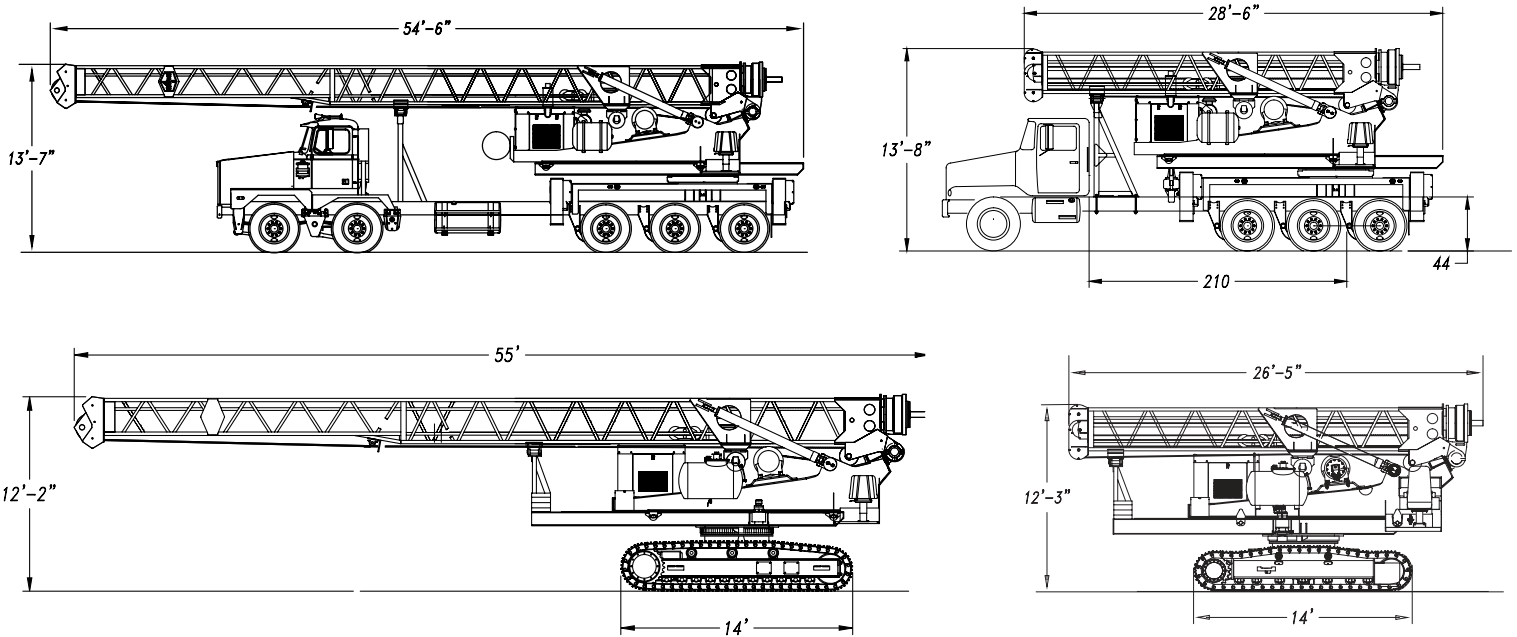

Sales Manager

Tony Kraut
817-927-8486 x336
Cell 469-586-7214
tony@watsonusa.com

Southeastern USA

Steve Drury
817-927-8486 x323
Cell 817-944-6577
steve@watsonusa.com

Northeastern USA

Jill Kennedy
Cell 443-401-0035
jill@watsonusa.com

Western USA

Scooter Scogins
817-927-8486 x350
Cell 817-307-9260
scooter.scogins@watsonusa.com

Parts Sales

Robert Broom
817-927-8486 x366
robert.broom@watsonusa.com

Customer Service Manager

Randy Cofer
817-927-8486 x335
Cell 817-247-8351
randy.cofer@watsonusa.com



Watson Drill Rigs

4015 South Freeway
Fort Worth, Texas 76110
800-927-8486
Fax 817-927-8716
sales@watsonusa.com